



Japan International Aerospace Exhibition 2016

October 12 (Wed.) to 15 (Sat.) 2016

Guide to Exhibit

Organizers: The Society of Japanese Aerospace Companies (SJAC)
Tokyo Big Sight Inc.

1 Basic Booth

(1 unit=9㎡)

(excluding tax)
Exhibition booth fee JPY **472,500**

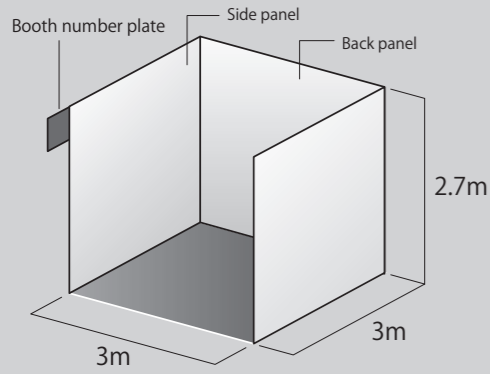

Example

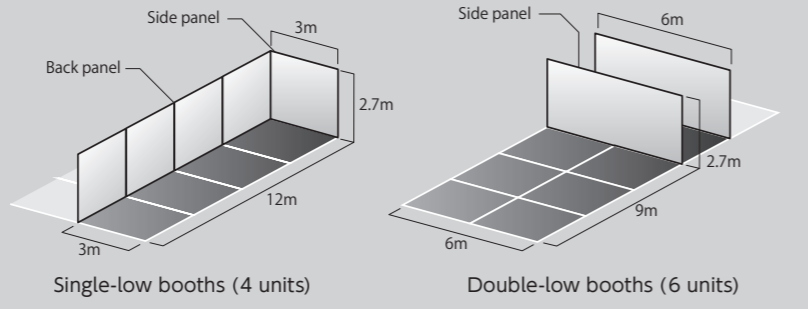

2 Island Booths in ㎡

(90㎡ or larger) price per ㎡ JPY **52,500**

Example : 10m × 10m booth (100㎡)

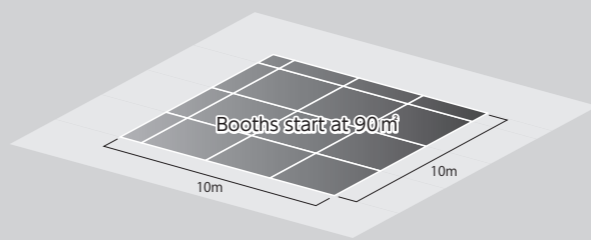

- ① Exhibits start at 90㎡
- ② We guarantee that island booths are non-adjacent to other booths

3 Outdoor Booth

(36㎡ or larger) price per ㎡ JPY **21,000**

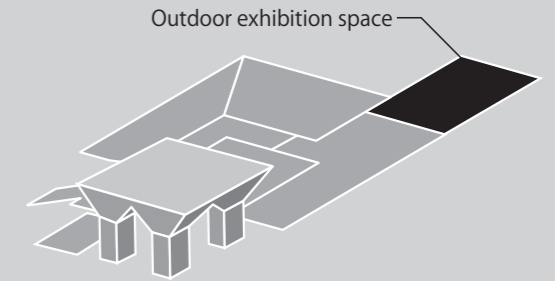

- ① Outdoor booths start at 36㎡.
- ② Applications may sometimes be denied based on organizational circumstances.

Package Booth

1- ① 1 Booth Type A JPY **570,000**

(excluding tax)

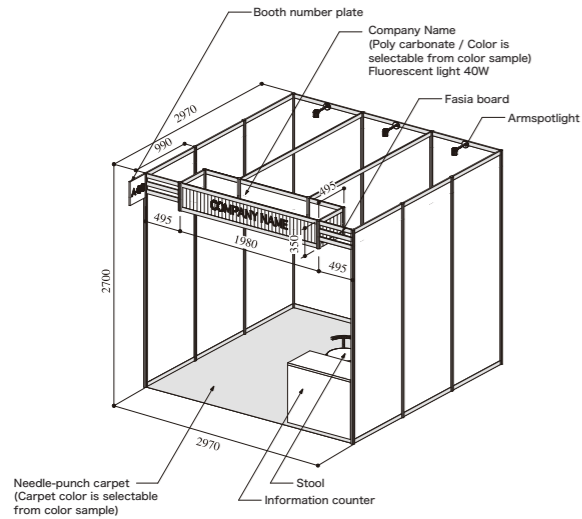

1 Booth Type A (9㎡)

No.	Item Name	Quantity
1	Needle-punch carpet	1 booth
2	Fasia board	1
3	Company Name	1
4	Information counter	1
5	Stool	1
6	Fluorescent light 40W	1
7	Arm spotlight	3
8	Outlet (100v600w)	1
9	Electric construction fee of main line	1kw

* The above price does not include electric construction fee of main line for more than 1kw.

Package Booth

1- ② 1 Booth Type B JPY **590,000**

(excluding tax)

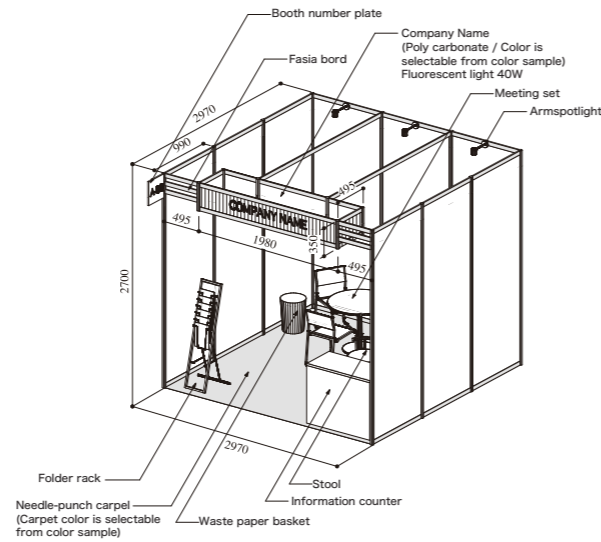

1 Booth Type B (9㎡)

No.	Item Name	Quantity
1	Needle-punch carpet	1 booth
2	Fasia board	1
3	Company Name	1
4	Information counter	1
5	Stool	1
6	Fluorescent light 40W	1
7	Arm spotlight	3
8	Outlet (100v600w)	1
9	Electric construction fee of main line	1kw
10	Folder rack	1
11	Meeting set: (Round table × 1, Stacking chair × 3)	1
12	Waste paper basket	1

* The above price does not include electric construction fee of main line for more than 1kw.

Package Booth

1- ③ 2 Booths Type A JPY **1,100,000**

(excluding tax)

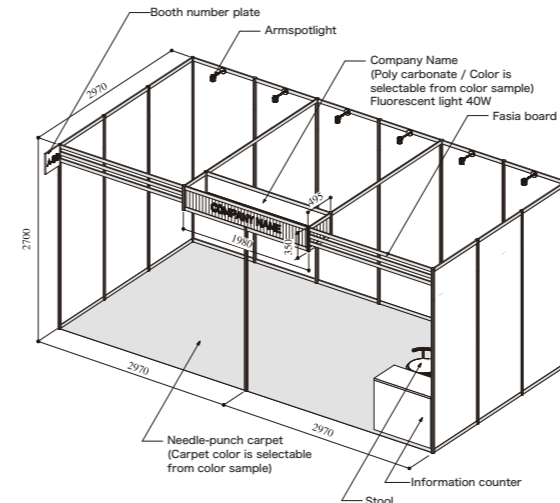

2 Booths Type A (18㎡)

No.	Item Name	Quantity
1	Needle-punch carpet	2 booths
2	Fasia board	1
3	Company Name	1
4	Information counter	1
5	Stool	1
6	Fluorescent light 40W	1
7	Arm spotlight	6
8	Outlet (100v600w)	2
9	Electric construction fee of main line	2kw

* The above price does not include electric construction fee of main line for more than 2kw.

Package Booth

1- ④ 2 Booths Type B JPY **1,150,000**

(excluding tax)

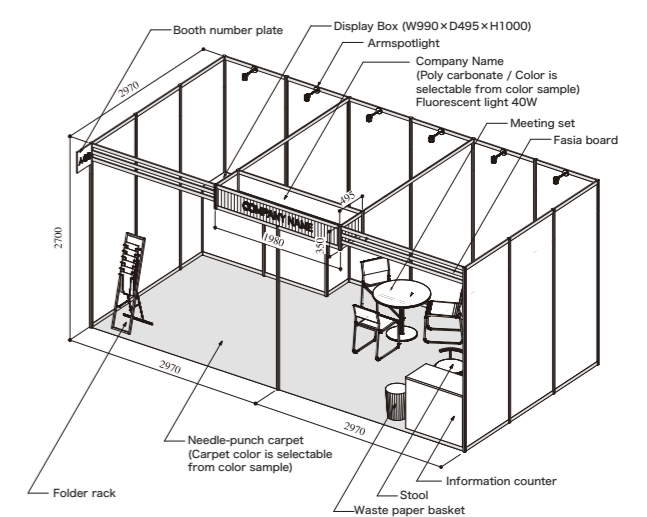

2 Booths Type B (18㎡)

No.	Item Name	Quantity
1	Needle-punch carpet	2 booths
2	Fasia board	1
3	Company Name	1
4	Information counter	1
5	Stool	1
6	Fluorescent light 40W	1
7	Arm spotlight	6
8	Outlet (100v600w)	2
9	Electric construction fee of main line	2kw
10	Folder rack	1
11	Meeting set: (Round table × 1, Stacking chair × 3)	1
12	Waste paper basket	1
13	Display Box (W990 × D495 × H1000)	2

* The above price does not include electric construction fee of main line for more than 2kw.

Exhibitor Fee Overview

No.	Type	Fee (excluding tax)	Note
1	Basic Booth	JPY472,500 /Unit	(1 unit = 9㎡)
	① Package Booth · 1 Booth type A	JPY570,000	
	② Package Booth · 1 Booth type B	JPY590,000	
	③ Package Booth · 2 Booths type A	JPY1,100,000	
	④ Package Booth · 2 Booths type B	JPY1,150,000	
2	Island Booth in ㎡	JPY52,500 /㎡	[requirement] Booth minimum 90㎡
3	Outdoor Booth	JPY21,000 /㎡	[requirement] Booth minimum 36㎡

Discounts for Large Indoor Display Items

Type	Discounted item	Discount amount	Note
Large indoor display item (actual model or mock up)	Item area (length x width)	(JPY52,500/㎡) x display item area x 50%	[requirement] display item area from 36㎡

* All furnishings, tools, sponsorships etc. are not covered by the discounts.

How to apply

1) Making an application

Please enter all required information into the included exhibitor application form and send it to the address below.

※ Applications can also be made through our website:

<http://www.japanaerospace.jp/eng>

2) Application deadline

Application deadline April 28(Thu.), 2016 However, if exhibitor spaces run out we will be forced to refuse new applications

3) Method of payment

An Invoice will be sent upon confirmation of the exhibitor's application details.

① Application fee (10% of the total exhibitor fee + consumption tax)

Payment deadline 30 days from issue of application confirmation notice.

② Remaining exhibitor fee (remaining sum to be paid after payment of the application fee)

Payment deadline May 31(Tue.), 2016

※ Applicant is responsible for any transfer fees or commission.

4) Cancellation

Once an application is accepted, withdrawal is not allowed in principle.

If the organizer deems it legitimate, the application may be withdrawn with cancellation fee the below.

Time of cancellation notice	cancellation fee
October 30(Fri.), 2015 - May 31(Tue.), 2016	10% of exhibitor fee
June 1(Wed.), 2016 - Day of event	100% of exhibitor fee

[Points to note]

1) Included in Exhibit Space Fee

- ① Exhibit space, back panels, side panels, and booth number plate
- ② Invitation ticket *Quantity is determined by booth size.
- ③ Operation and promotion of the exhibition by the organizer
- ④ Exposure through exhibitors list on official floor map and handouts
- ⑤ Safety management and security guard fees

2) Not Included in the Exhibitor Fee

- ① Decoration, construction, and operation fee of each booth
- ② Construction fee and any other charge of electricity, water, gas, etc. for each booth
- ③ Fee of advertisement on official guidebook
- ④ Damage insurance on exhibits, etc.
- ⑤ Expense for injuries arising during exhibition, demonstration or transporting of exhibits, etc.
- ⑥ Expense for renovating booth decoration, structure, etc. required by regulations and exhibition rules.
- ⑦ Other expense not listed on " 1) Included in Exhibit Space Fee."

3) Allotment

The organizer decides booth allocation taking exhibits, booth size, demonstration plans, dates of application, etc. into the consideration.

Schedule

April 2015

Start of application period

April 2016

Application deadline

May 2016

Exhibitor fee payment deadline

June 2016 (planned)

Exhibitor briefing
Exhibitor manual distribution
Announcement of booth layout

October 12-15, 2016

Japan International Aerospace Exhibition 2016

Contact

<http://www.japanaerospace.jp/eng>

Tokyo Big Sight Inc.

Japan International Aerospace Exhibition Office

3-11-1 Ariake, Koto-ku, Tokyo 135-0063 JAPAN

TEL: +81-3-5530-1358 FAX : +81-3-5530-1222

E-mail: bigstight-ja@tokyo-bigstight.co.jp